

**SADEV**  
RACING TRANSMISSION

RANGE  
**2WD**  
2 WHEEL DRIVE

**ST75LW**  
TRANSVERSE

The ST75 LW has been designed in order to renew SADEV's bestseller with the updated manufacturing process. The new version of the ST75-14 allows SADEV to make a technological step forward and offers the most elaborated product of its range (oil pump, differential, ratios). The optimisation of the design of the casings allow SADEV to gain weight by keeping the same robustness, all at an unbeatable price.

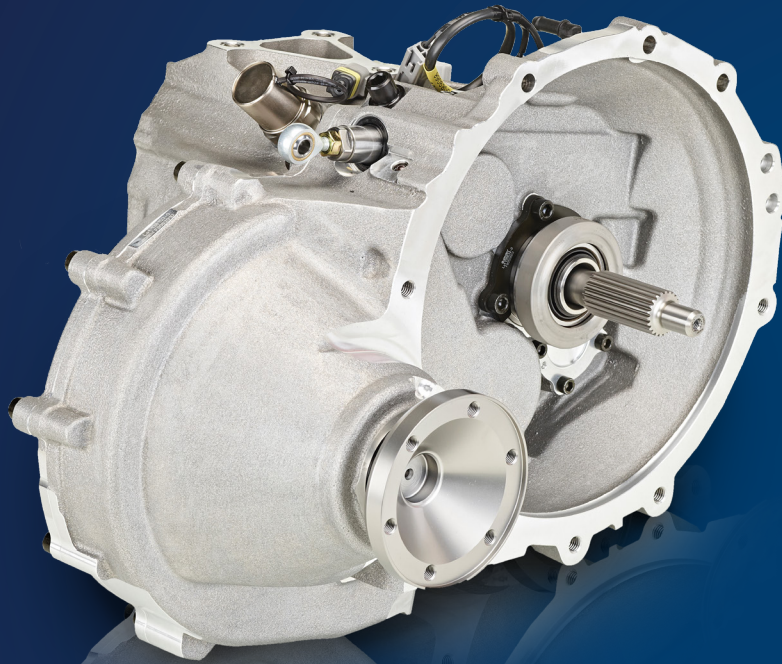

## APPLICATIONS

- › Circuit
- › Hill Climb
- › Rallycross
- › Rally



## TECHNICAL SPECS

5 or 6 speed sequential gearbox + 1 reverse gear

Manual sequential gear selection

Wide range of final drives available

Wide range of ratios available

Straight cut gears

Gear engagement made by dogs

Interchangeable gear ratios

High strength carburizing steel

Gear teeth grinded with optimized profile

Shot penning on internal parts

Specific input shaft

Limited slip differential (free differential optional)

Ramp and plate system - 3 discs type

Preload made by belleville spring washer

Wide range of ramp plates available

Reverse lockout cable (solenoid system optional)

Contactless gear position sensor

Flat shift sensor

Splash lubrication system

Integrated oil pump (optional)

Oil suction screen

Magnetic drain plugs

AS7G aluminum casings

Weight (input shaft included): 32kg - 70lbs

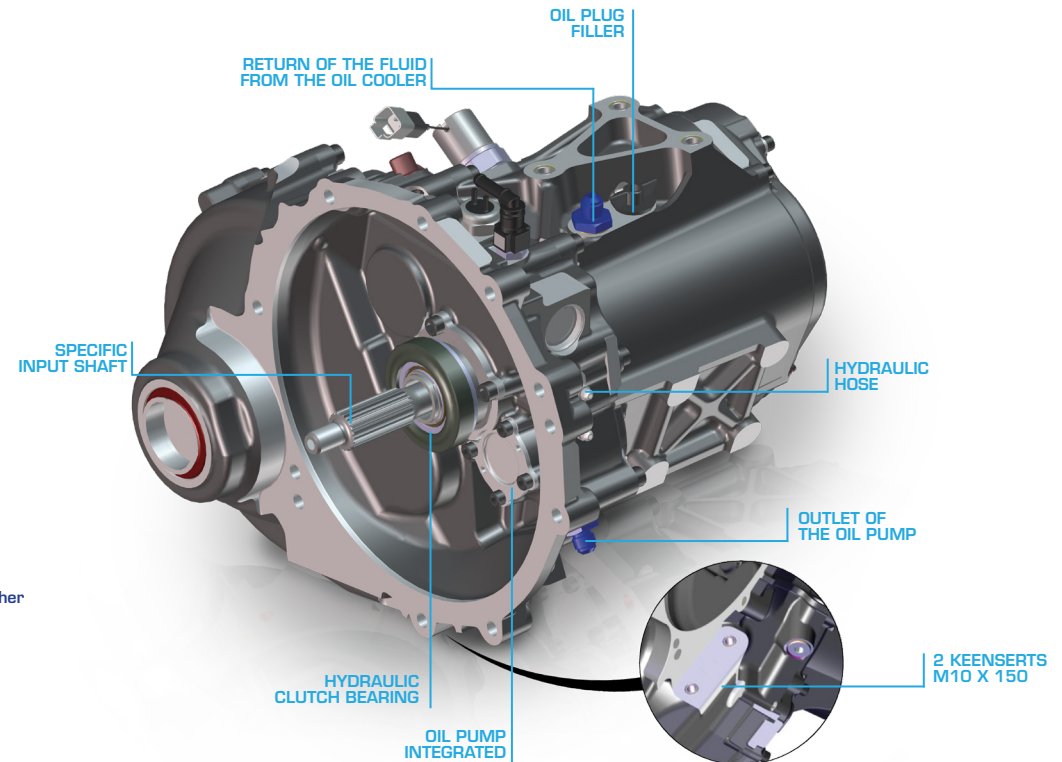
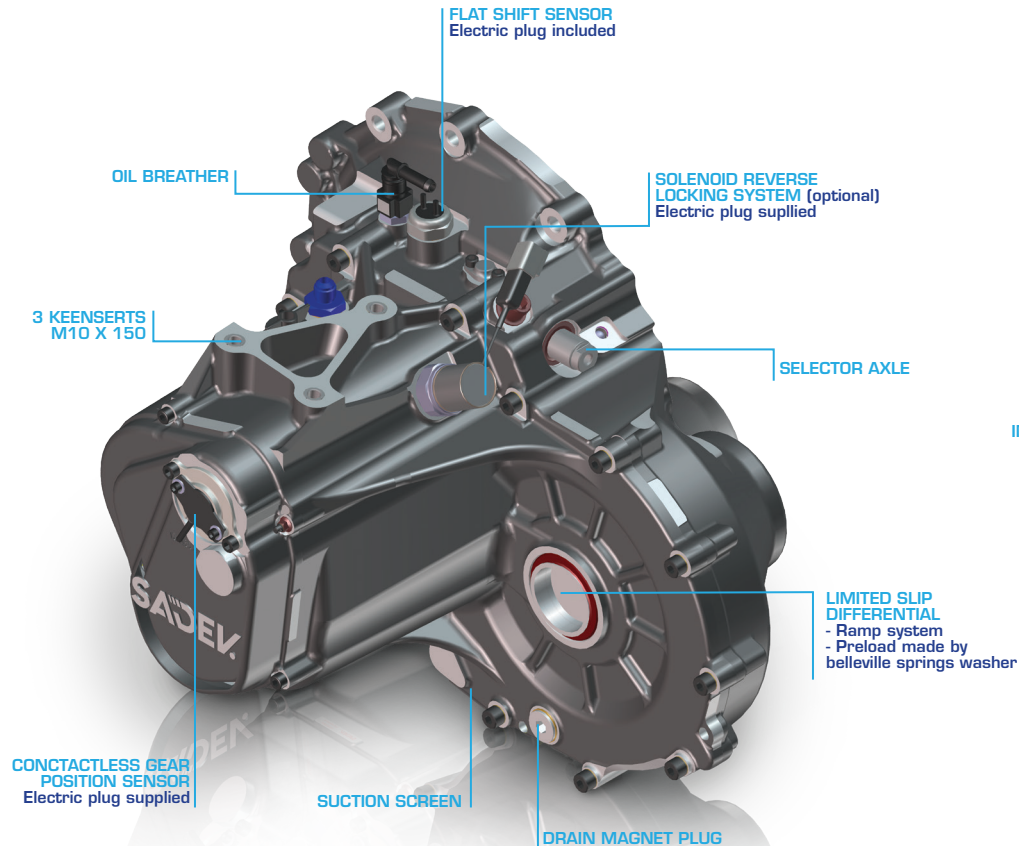



## ACCESSORIES

- › Gear display
- › Driven tripod flange
- › Adaptator plate
- › Gearlever
- › Drive shafts

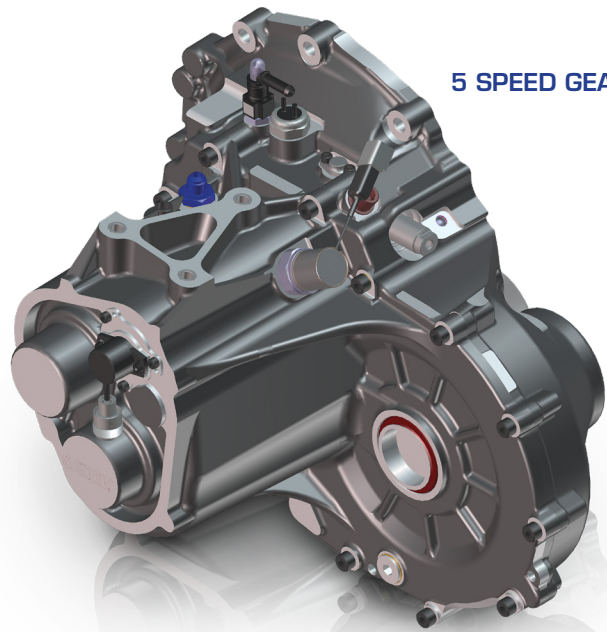

5 SPEED GEARBOX VERSION



6 SPEED GEARBOX VERSION

REMOVABLE CLUTCH SHAFT

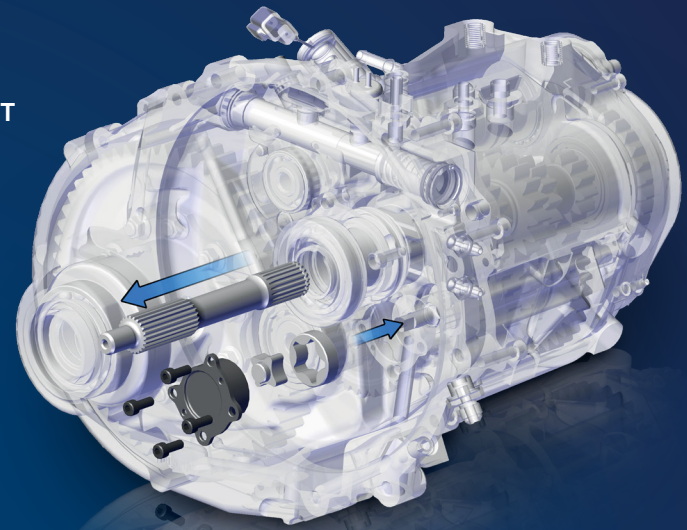

INTEGRATED OIL PUMP  
(OPTIONAL)

LIMITED SLIP DIFFERENTIAL

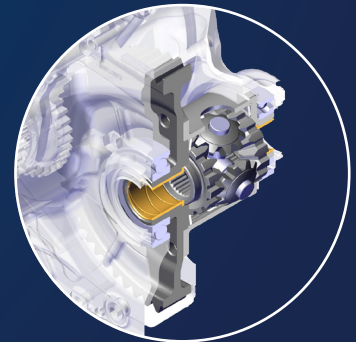

FREE DIFFERENTIAL



## ST75LW TRANSVERSE

› **Experience:** The ST75LW has been created based on ST75-14's feedback, a SADEV's best seller. This new gearbox inherits the ST75-14 qualities in a more accomplished version.

› **Ratio selection:** Optimised clutch and control shaft definition for smoother gear shifting. Available in 5 or 6 speed versions.

› **Differential:** A free differential version is available for categories with cost limits. This differential can be replaced with a limited slip version.

› **Robustness:** Our finite element calculation tool enables us to design extremely strong, compact, lightweight casings.

› **Cooling :** An oil pump can be integrated with the ST75LW. Driven mechanically, this enables an external oil cooler to be connected.

› **Weight:** Significant weight advantage compared to the ST75-14. The lightest product on the market in its range.

### MAXIMUM ENGINE TORQUE

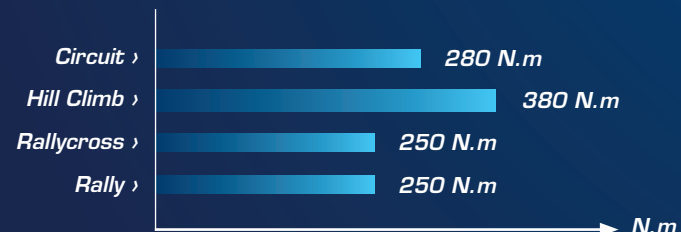





## ONE PASSION : VICTORY

SADEV has an exceptional record in supplying unique engineering to the most prestigious drivers and manufacturers. SADEV's products stand out for their technology, their excellence and their ambition. As precise as they are reliable, these high-tech masterpieces are the key to your victory. SADEV has just one goal: to make sure you win.

FOLLOW US



[WWW.SADEV-TM.COM](http://WWW.SADEV-TM.COM)

6, rue Grand'Montains - 85110 SAINT-PROUANT - FRANCE

Tel: +33 (0)2 51 66 42 68

[sadev@sadev-tm.com](mailto:sadev@sadev-tm.com)



## A TEAM AT YOUR SIDE

<b>FRANCE</b>	SADEV FRANCE - <a href="mailto:sadev@sadev-tm.com">sadev@sadev-tm.com</a>
<b>USA</b>	SADEV TRANSMISSIONS, INC. - <a href="mailto:info.usa@sadev-tm.com">info.usa@sadev-tm.com</a>
<b>UK</b>	SWR MOTORSPORT LTD - <a href="mailto:servicesswrmotorsport@gmail.com">servicesswrmotorsport@gmail.com</a>
<b>ITALY</b>	GIEFFE RACING - <a href="mailto:info@giefferacing.com">info@giefferacing.com</a>
<b>SPAIN</b>	DE LA PUENTE MOTORSPORT - <a href="mailto:dlpmotorsport@movistar.es">dlpmotorsport@movistar.es</a>
<b>NETHERLANDS</b>	RACING DEVELOPMENT - <a href="mailto:info@racingdevelopment.nl">info@racingdevelopment.nl</a>
<b>NETHERLANDS</b>	PETERS AUTOSPORT - <a href="mailto:bart@petersautosport.nl">bart@petersautosport.nl</a>
<b>BELGIUM</b>	R TEC - <a href="mailto:info@rtec.ws">info@rtec.ws</a>
<b>CZECH REPUBLIC</b>	SADAC - <a href="mailto:info@sadac.cz">info@sadac.cz</a>
<b>GERMANY</b>	MTO ENGINEERING - <a href="mailto:info@mtoengineering.com">info@mtoengineering.com</a>
<b>SWEDEN</b>	HANSEN MOTORSPORT - <a href="mailto:kenneth@hansen-motorsport.se">kenneth@hansen-motorsport.se</a>
<b>DENMARK</b>	GUNNAR AASKOV MOTORSPORT - <a href="mailto:mail@aaaskov-motorsport.dk">mail@aaaskov-motorsport.dk</a>
<b>FINLAND</b>	SET PROMOTION - <a href="mailto:kalle.pinomaki@setpromotion.com">kalle.pinomaki@setpromotion.com</a>
<b>SWITZERLAND</b>	CHRISTIAN FERRARI - <a href="mailto:ferrach@bluewin.ch">ferrach@bluewin.ch</a>
<b>SOUTH AFRICA</b>	CENTURY RACING - <a href="mailto:julien@centuryracing.co.za">julien@centuryracing.co.za</a>
<b>ARGENTINA</b>	JPO RACING - <a href="mailto:racingjpo@gmail.com">racingjpo@gmail.com</a>
<b>BRAZIL</b>	CD MOTORSPORT ENGINEERING - <a href="mailto:sadev.brasil@gmail.com">sadev.brasil@gmail.com</a>
<b>PORTUGAL</b>	AUTO PAMPLONA, LDA - <a href="mailto:info@autopamplona.com">info@autopamplona.com</a>

RANGE  
**2WD**  
2 WHEEL DRIVE



 **ST75LW**  
TRANSVERSE

**SADEV**<sup>®</sup>  
RACING TRANSMISSION